

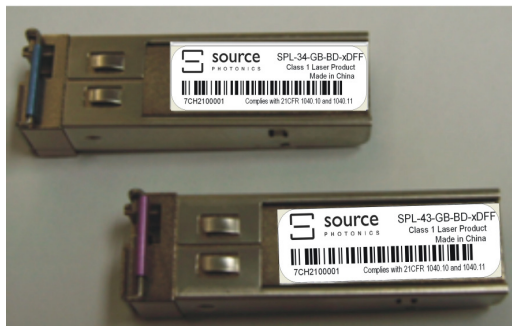

1.25Gbps Single Fiber Bi-directional SFP Transceiver

(For 40km point-to-point transmission)



Members of Flexon™ Family

Description

Source Photonics 1.25G single fiber bi-directional SFP transceivers are high performance, cost effective modules, which supports data rate of 1.25Gbps and transmission distance up to 40km.

SPL-34-GB-BD-xDFF is normally used in the client side (ONU), which transmits 1310nm optical signal and receives 1490nm optical signal. While SPL-43-GB-BD-xDFF is used in the central office side (OLT), which transmits 1490nm optical signal and receives 1310nm optical signal.

The standard serial ID information compatible with SFP MSA describes the transceiver's capabilities, standard interfaces, manufacturer and other information. The host equipment can access this information via the 2-wire serial CMOS EEPROM protocol. For further information, please refer to SFP MSA.

An enhanced Digital Diagnostic Monitoring Interface compatible with SFF-8472 has been incorporated into the transceivers. It allows real time access to the transceiver operating parameters such as transceiver temperature, laser bias current, transmitted optical power, received optical power and transceiver supply voltage by reading a built-in memory with I²C interface.

SPL-34-GB-BD-xDFF; SPL-43-GB-BD-xDFF are compliant with RoHS.

Features

- ◆ 1.25Gbps bi-directional data links
- ◆ Up to 40km point-to-point transmission
- ◆ 1310nm DFB transmitter and 1490nm PIN receiver for SPL-34-GB-BD-xDFF
- ◆ 1490nm DFB transmitter and 1310nm PIN receiver for SPL-43-GB-BD-xDFF
- ◆ Class I laser product
- ◆ Low EMI and excellent ESD protection
- ◆ SFP MSA package with single LC receptacle
- ◆ Single +3.3V Power Supply
- ◆ Detailed product information in EEPROM
- ◆ Operating Case Temperature
 - Commercial temperature: -5 to +70°C
 - Extended temperature: -5 to +85°C
 - Industrial temperature: -40 to +85°C

Applications

- ◆ Gigabit Ethernet Application
- ◆ Point-to-Point FTTX Application

Standard

- ◆ Compatible with SFP MSA
- ◆ Refer to IEEE 802.3ah -2004
- ◆ Compatible with Digital Diagnostic SFF-8472
- ◆ Compatible with Bellcore GR-468
- ◆ Compatible with FDA 21 CFR 1040.10 and 1040.11, Class I
- ◆ RoHS compliance

Regulatory Compliance

The transceivers have been tested according to American and European product safety and electromagnetic compatibility regulations (See Table 1). For further information regarding regulatory certification, please refer to Source Photonics regulatory specification and safety guidelines, or contact with Source Photonics, Inc. America sales office listed at the end of documentation.

Table 1 - Regulatory Compliance

Feature	Standard	Performance
Electrostatic Discharge (ESD) to the Electrical Pins	MIL-STD-883E Method 3015.7	Class 1
Electrostatic Discharge (ESD) to the Duplex LC Receptacle	IEC 61000-4-2	Compatible with standard
Electromagnetic Interference (EMI)	FCC Part 15 Class B	Compatible with standard
Laser Eye Safety	FDA 21CFR 1040.10 and 1040.11 EN (IEC) 60825-1,2	Compatible with Class 1 laser product.
RoHS	2002/95/EC 4.1&4.2 2005/747/EC	Compliant with RoHS

Absolute Maximum Ratings

Absolute Maximum Ratings are those values beyond which damage to the devices may occur.

Table 2 – Absolute Maximum Ratings

Parameter	Symbol	Min.	Max.	Unit	Note
Storage Temperature	T_s	-40	+85	°C	
Operating Case Temperature	T_c	-5	+70	°C	1
		-5	+85		2
		-40	+85		3
Supply Voltage	V_{CC}	0	4	V	
Input Voltage	V_{in}	0	V_{CC}	V	

Note

- SPL-34-GB-BD-CDFF SPL-43-GB-BD-CDFF
- SPL-34-GB-BD-EDFF SPL-43-GB-BD-EDFF
- SPL-34-GB-BD-IDFF SPL-43-GB-BD-IDFF

Recommended Operating Conditions

Table 3 - Recommended Operating Conditions

Parameter	Symbol	Min.	Typical	Max.	Unit	Note
Operating Case Temperature	T_c	-5		+70	°C	1
		-5		+85		2

		-40		+85		3
Power Supply Voltage	V _{CC}	3.13	3.3	3.47	V	
Power Supply Current	I _{CC}			300	mA	
Data Rate			1.25		Gbps	

1. SPL-34-GB-BD-CDFF SPL-43-GB-BD-CDFF
2. SPL-34-GB-BD-EDFF SPL-43-GB-BD-EDFF
3. SPL-34-GB-BD-IDFF SPL-43-GB-BD-IDFF

SPL-34-GB-BD-xDFF (1310nm DFB Tx/1490nm PIN Rx for ONU, 40km)

Table 4 –Optical and Electrical Characteristics (Operating Case Temperature, V_{CC}=3.13 to 3.47V)

Parameter	Symbol	Min.	Typical	Max.	Unit	Note
Transmitter						
Centre Wavelength	λ_C	1260	1310	1360	nm	
Average Launch Power	P _{Out}	-2		+3	dBm	1
Average Launch Power of OFF Transmitter				-45	dBm	
Spectral Width (-20dB)	$\Delta\lambda$			1	nm	
Side Mode Suppression Ratio	SMSR	30			dB	
Extinction Ratio	EX	6			dB	
Rise/Fall Time (20%~80%)	tr /tf			0.26	ns	
Relative Intensity Noise	RIN ₁₂ OMA			-113	dB/Hz	
Optical Return Loss tolerance				12	dB	
Deterministic Jitter	DJ			200	ps	
Total Jitter	TJ			385	ps	
Output Optical Eye	IEEE 802.3ah Compatible					2
Single Ended Data Input Swing	V _{IN}	250		1200	mV	3
Input Differential Impedance	Z _{IN}	80	100	120	Ω	
TX Disable	Disable		2.0		V _{CC}	V
	Enable		0		0.8	V
TX Fault	Fault		2.0		V _{CC} +0.3	V
	Normal		0		0.8	V
Receiver						
Centre Wavelength	λ_C	1480	1490	1500	nm	
Receiver Sensitivity				-23	dBm	4
Receiver Overload		-3			dBm	4
LOS De-Assert	LOS _D			-24	dBm	
LOS Assert	LOS _A	-35			dBm	6
LOS Hysteresis		0.5		4	dB	
Receiver Reflectance				-12	dB	
Single ended Data Output Swing	V _{OUT}	200		800	mV	5
LOS	High		2		V _{CC} +0.3	V
	Low		0		0.8	V

Note:

1. The optical power is launched into SMF.
2. Measured with a PRBS 2^7-1 test pattern @1.25Gbps.
3. Internally AC coupled and terminated.
4. Measured with a PRBS 2^7-1 test pattern@1.25Gbps, $BER \leq 1 \times 10^{-12}$.
5. Internally AC coupled.
6. Rx_LOS is guaranteed to occur if input power is lower than -35dBm.

SPL-43-GB-BD-xDFF (1490nm DFB Tx/1310nm PIN Rx for OLT, 40km)

Table 5 –Optical and Electrical Characteristics (Operating Case Temperature, $V_{CC}=3.13$ to $3.47V$)

Parameter	Symbol	Min.	Typical	Max.	Unit	Note
Transmitter						
Centre Wavelength	λ_C	1480	1490	1500	nm	
Average Launch Power	P_{Out}	-2		+3	dBm	1
Average Launch Power of OFF Transmitter				-45	dBm	
Spectral Width (-20dB)	$\Delta\lambda$			1	nm	
Side Mode Suppression Ratio	SMSR	30			dB	
Extinction Ratio	EX	6			dB	
Rise/Fall Time (20%~80%)	tr /tf			0.26	ns	
Relative Intensity Noise	RIN_{12OMA}			-113	dB/Hz	
Optical Return Loss tolerance				12	dB	
Deterministic Jitter	DJ			200	ps	
Total Jitter	TJ			385	ps	
Output Optical Eye	IEEE 802.3ah Compatible					2
Single Ended Data Input Swing	V_{IN}	250		1200	mV	3
Input Differential Impedance	Z_{IN}	80	100	120	Ω	
TX Disable	Disable		2.0		V_{CC}	V
	Enable		0		0.8	V
TX Fault	Fault		2.0		$V_{CC}+0.3$	V
	Normal		0		0.8	V
Receiver						
Centre Wavelength	λ_C	1260	1310	1360	nm	
Receiver Sensitivity				-23	dBm	4
Receiver Overload		-3			dBm	4
LOS De-Assert	LOS_D			-24	dBm	
LOS Assert	LOS_A	-35			dBm	6
LOS Hysteresis		0.5		4	dB	
Receiver Reflectance				-12	dB	
Single Ended Data Output Swing	V_{OUT}	200		800	mV	5
LOS	High		2.0		$V_{CC}+0.3$	V
	Low		0		0.8	V

Note:

1. The optical power is launched into SMF.

2. Measured with a PRBS 2^7-1 test pattern @1.25Gbps.
3. Internally AC coupled and terminated.
4. Measured with a PRBS 2^7-1 test pattern@1.25Gbps, $BER \leq 1 \times 10^{-12}$
5. Internally AC coupled.
6. Rx_LOS is guaranteed to occur if input power is lower than -35dBm.

EEPROM Information

The SFP MSA defines a 256-byte memory map in EEPROM describing the transceiver's capabilities, standard interfaces, manufacturer, and other information, which is accessible over a 2 wire serial interface at the 8-bit address 1010000X (A0h). For the memory contents, Please refer to Table 6.

Table 6 - EEPROM Serial ID Memory Contents (A0h)

Addr.	Field Size (Bytes)	Name of Field	Hex	Description
0	1	Identifier	03	SFP
1	1	Ext. Identifier	04	MOD4
2	1	Connector	07	LC
3—10	8	Transceiver	00 00 00 40 00 00 00 00	Transmitter Code
11	1	Encoding	01	8B10B
12	1	BR, nominal	0D	1.25Gbps
13	1	Reserved	00	
14	1	Length (9um)-km	28	40km
15	1	Length (9um)	FF	40km
16	1	Length (50um)	00	
17	1	Length (62.5um)	00	
18	1	Length (copper)	00	
19	1	Reserved	00	
20—35	16	Vendor name	53 4F 55 52 43 45 50 48 4F 54 4F 4E 49 43 53 20	"SOURCEPHOTONICS"(ASC II)
36	1	Reserved	00	
37—39	3	Vendor OUI	00 00 00	
40—55	16	Vendor PN	53 50 4C xx xx 47 42 42 44 xx 44 46 46 20 20 20	"SPLxxGBBDxDFF" (ASC II)
56—59	4	Vendor rev	xx xx xx xx	ASC II ("31 30 20 20" means 1.0 revision)
60-61	2	Wavelength	05 1E/05 D2	1310/1490nm
62	1	Reserved	00	
63	1	CC_BASE	xx	Check sum of bytes 0 - 62
64—65	2	Options	00 1A	LOS, TX_FAULT and TX_DISABLE
66	1	BR, max	00	
67	1	BR, min	00	
68—83	16	Vendor SN	xx xx xx xx xx xx xx xx	ASC II

			xx xx xx xx xx xx xx xx	
84—91	8	Vendor date code	xx xx xx xx xx xx 20 20	Year(2 bytes), Month(2 bytes), Day (2 bytes)
92	1	Diagnostic type	58	Diagnostics(Ext.Cal)
93	1	Enhanced option	B0	Diagnostics (Optional Alarm/warning flags, Soft TX_FAULT and Soft TX_LOS monitoring)
94	1	SFF-8472	02	Diagnostics(SFF-8472 Rev 9.4)
95	1	CC EXT	xx	Check sum of bytes 64 - 94
96—255	160	Vendor specific		

Note: The “xx” byte should be filled in according to practical case. For more information, please refer to the related document of SFF-8472 Rev 9.5.

Monitoring Specification

The digital diagnostic monitoring interface also defines another 256-byte memory map in EEPROM, which makes use of the 8 bit address 1010001X (A2h). Please see Figure 1. For detail EEPROM information, please refer to the related document of SFF-8472 Rev 9.5. The monitoring specification of this product is described in Table 7.

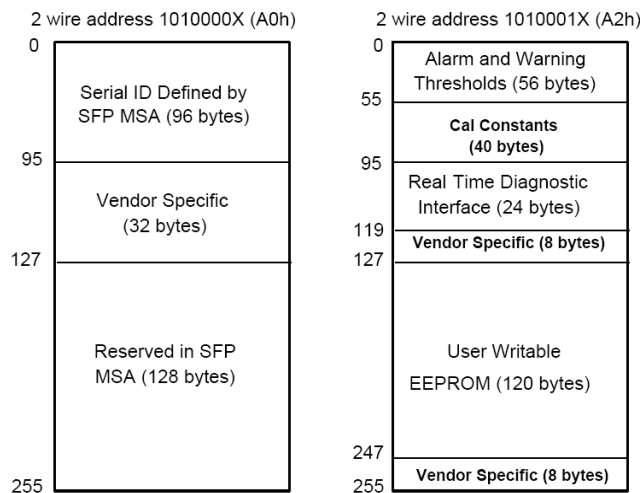

Figure 1, EEPROM Memory Map Specific Data Field Description

Table 7 - Monitoring Specification

Parameter		Range	Accuracy	Calibration
Temperature	SPL-34-GB-BD-CDFF	-5 to + 90°C	±3°C	External
	SPL-43-GB-BD-CDFF			
	SPL-34-GB-BD-EDFF	-10 to + 100°C		
	SPL-43-GB-BD-EDFF			
SPL-34-GB-BD-IDFF	-40 to +100°C			
SPL-43-GB-BD-IDFF				
Voltage		2.97 to 3.63V	±3%	External

Bias Current	3mA to 80mA	±10%	External
TX Power	-2 to +3dBm	±3dB	External
RX Power	-3 to -23dBm	±3dB	External

Recommended Interface Circuit

Figure 2 shows the recommended interface circuit.

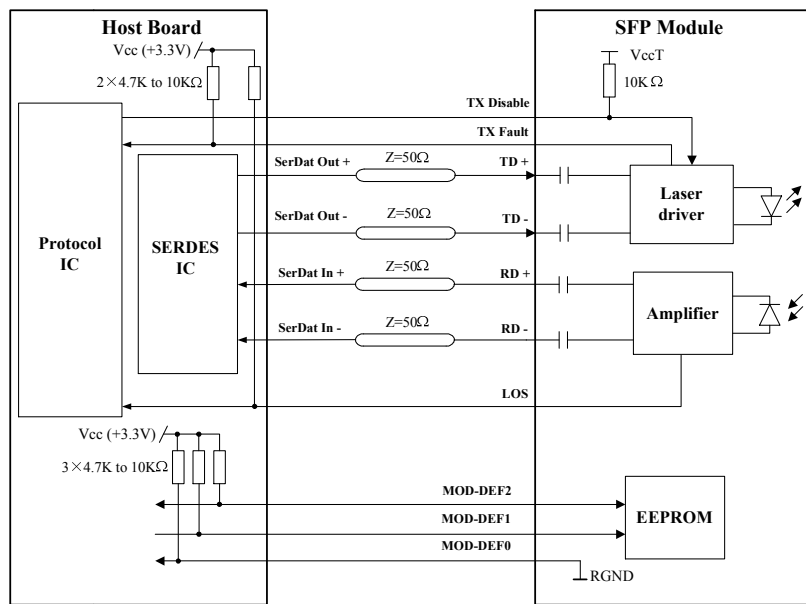

Figure 2, Recommended Interface Circuit

Pin Definitions

The pin functions are described in Table 8 with the accompanying notes.

Table 8 – Pin Function Definitions

Pin	Function	Notes
1	VeeT	TX GND
2	TX-FAULT	Open Collector
3	TX-DISABLE	Internally Pulled High
4	MOD-DEF2	Serial Data Input
5	MOD-DEF1	Serial Clock Input
6	MOD-DEF0	Internally Grounded
7	NC	Not Connected
8	LOS	Open Collector
9	VeeR	RX Ground
10	VeeR	RX Ground
11	VeeR	RX Ground
12	RXD-	RX Data Negative

13	RXD+	RX Data Positive
14	VeeR	RX GND
15	VccR	RX Power
16	VccT	TX Power
17	VeeT	TX GND
18	TXD+	TX Data Positive
19	TXD-	TX Data Negative
20	VeeT	TX GND

Mechanical Design Diagram

The mechanical design diagram is shown in Figure 3

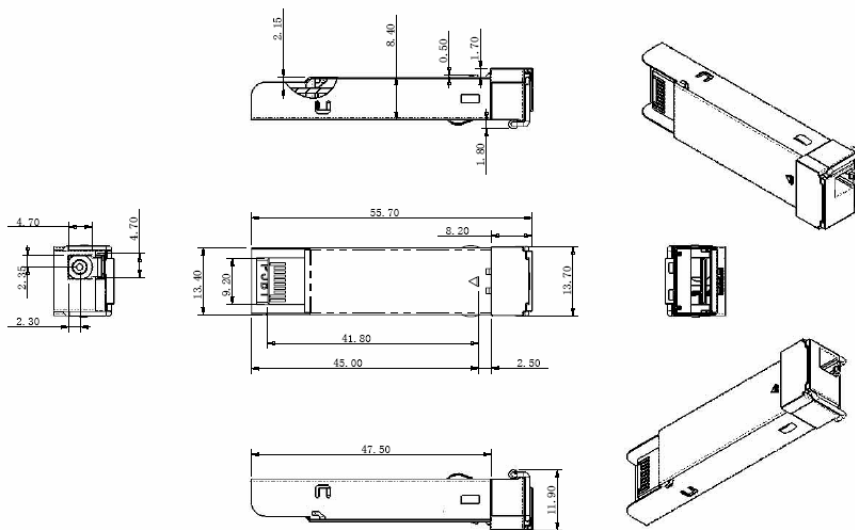
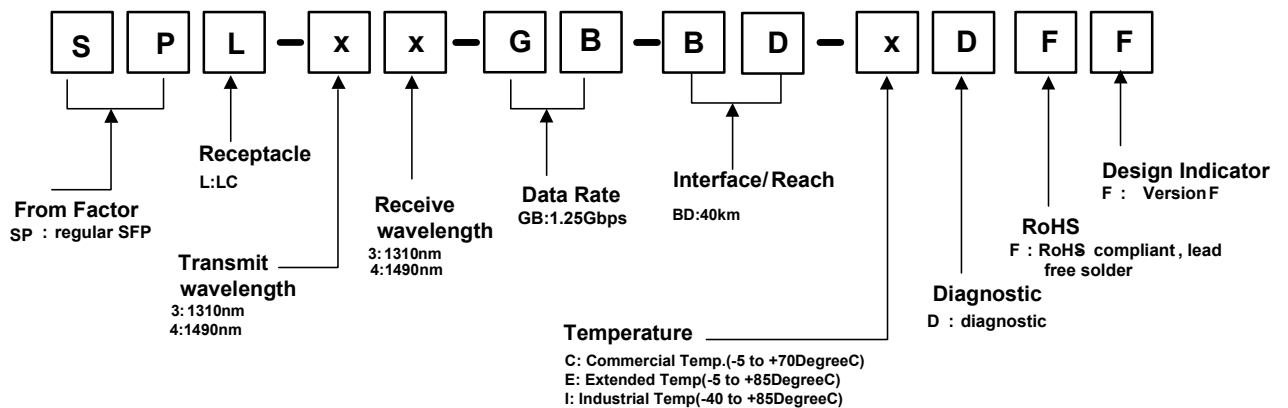

Figure 3, Mechanical Design Diagram of SFP with Spring Latch

Ordering information



Part No.	Product Description
SPL-34-GB-BD-CDFF	1310nm Tx/1490nm RX for ONU, 1.25Gbps, 40km, SFP with Spring latch, LC receptacle, -5°C~+70°C, Compliant with RoHS
SPL-43-GB-BD-CDFF	1490nm Tx/1310nm RX for OLT, 1.25Gbps, 40km, SFP with Spring latch, LC receptacle, -5°C~+70°C, Compliant with RoHS
SPL-34-GB-BD-EDFF	1310nm Tx/1490nm RX for ONU, 1.25Gbps, 40km, SFP with Spring latch, LC receptacle, -5°C~+85°C, Compliant with RoHS
SPL-43-GB-BD-EDFF	1490nm Tx/1310nm RX for OLT, 1.25Gbps, 40km, SFP with Spring latch, LC receptacle, -5°C~+85°C, Compliant with RoHS
SPL-34-GB-BD-IDFF	1310nm Tx/1490nm RX for ONU, 1.25Gbps, 40km, SFP with Spring latch, LC receptacle, -40°C~+85°C, Compliant with RoHS
SPL-43-GB-BD-IDFF	1490nm Tx/1310nm RX for OLT, 1.25Gbps, 40km, SFP with Spring latch, LC receptacle, -40°C~+85°C, Compliant with RoHS

Related Documents

For further information, please refer to the following documents: *Flexon™ SFP Installation Guide*

- ◆ *Flexon™ SFP Installation Guide*
- ◆ *Flexon™ SFP Application Notes*
- ◆ *SFP Multi-Source Agreement (MSA)*

Obtaining Document

You can visit our website:

<http://www.Sourcephotonics.com>

Or contact with Sourcephotonics, Inc. America Sales Office listed at the end of documentation to get the latest documents.

© Copyright Source Photonics Inc. 2008

All Rights Reserved.

All information contained in this document is subject to change without notice. The products described in this document are NOT intended for use in implantation or other life support applications where malfunction may result in injury or death to persons.

The information contained in this document does not affect or change Source Photonics product specifications or warranties. Nothing in this document shall operate as an express or implied license or indemnity under the intellectual property rights of Source Photonics or third parties. All information contained in this document was obtained in specific environments, and is presented as an illustration. The results obtained in other operating environment may vary.

THE INFORMATION CONTAINED IN THIS DOCUMENT IS PROVIDED ON AN "AS IS" BASIS. In no event will Source Photonics be liable for damages arising directly from any use of the information contained in this document.

Contact

U.S.A. Headquarter:

20550 Nordhoff Street

Chatsworth, CA91311

U. S. A.

Tel: 818.773.9044

Fax: 818.773.0261

M-S@sourcephotonics.com.cn